

# "Astor" Mickey Grand-Chassis type DH

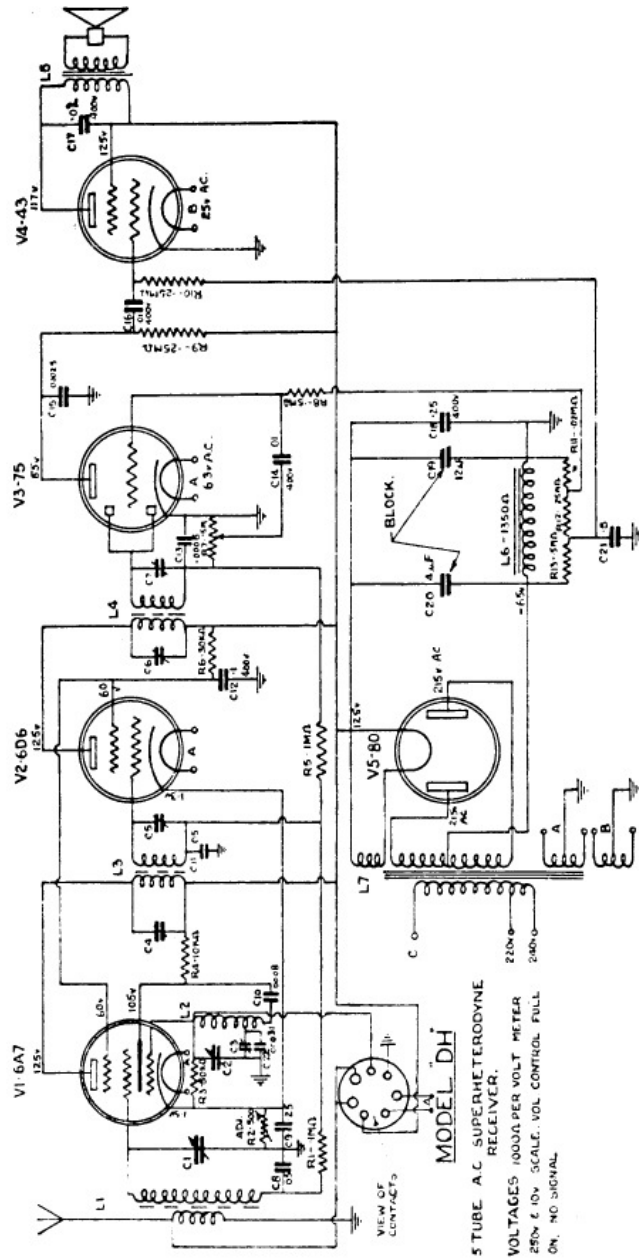

Astor "Mickey Grand," chassis type "DH," is a five-valve receiver designed for broadcast coverage and operation from 200-250 volts A.C. mains. This receiver is of the "table" type and is fitted with two panel controls—volume and tuning. In addition, an internal "sensitivity" control is provided in the form of R2 (500 ohms adjustable) which regulates the minimum bias applied to the converter and I.F. valves. The loudspeaker used is a 6 inch, 1.350 ohms field, unit. This receiver, in common with others in the "Mickey Mouse" series, is fitted with a 7-pin socket for connection of an Astor "Overseas-er."

## CIRCUIT NOTES

Although the circuit arrangement of this receiver is fairly straightforward, the use of a type 43 output pentode will be a surprise to those unaccustomed to "Astor" practice. This valve is, of course, a 25 v. heater type, and is normally used only in A.C./D.C. receivers. In this model, however, the designers have endeavoured to keep the high-tension supply voltage as low as possible, in order to increase the safety factor and reduce the heat dissipation—both important points in a compact chassis. Consequently, the use of a type 43 was indicated as it was, at the time, the only valve type available which was capable of delivering a reasonable power output at a low plate voltage. As a result of the design policy adopted, the highest D.C. voltage present in this receiver is approx. 180 v.—between rectifier filament and H.T. secondary C.T. 65 volts of this is dropped across the L.S. field, thus leaving a total H.T. supply of only 125 volts.

Final points of interest are the "bleed" biasing of both the 75 triode section and the 43. Grid bias for these valves is obtained from the voltage divider network across the L.S. field. Resistor R13 of this and condenser C25 also form an effective hum filter system.

The I.F. used in this receiver is exactly 456 KC.